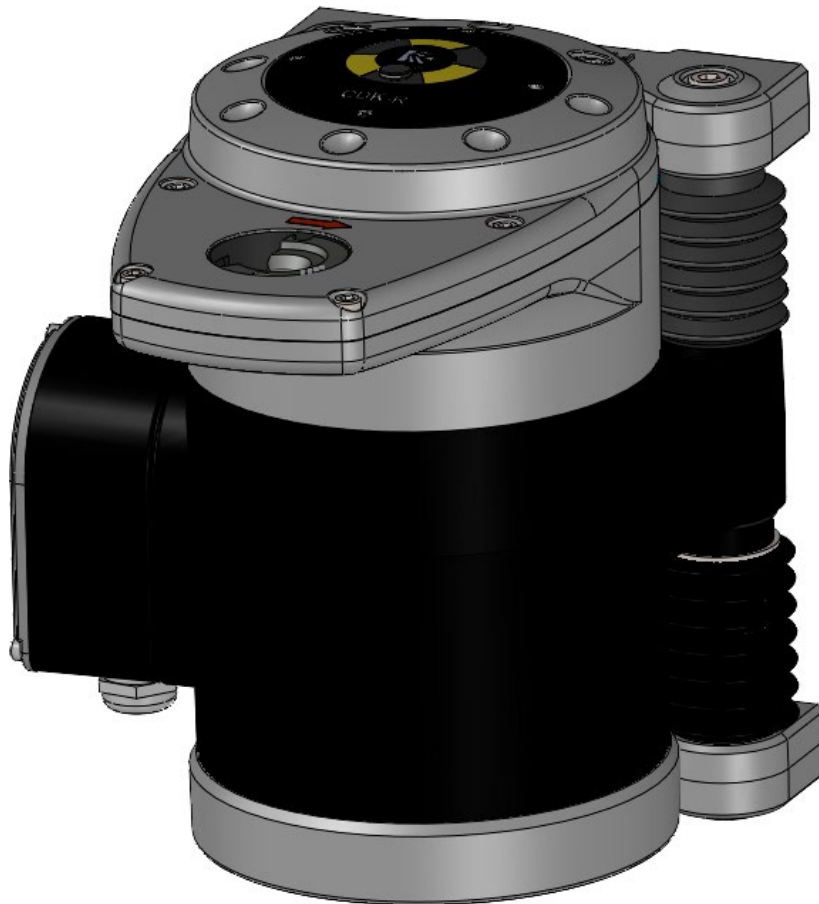




# High Speed Auto Tip Dresser (CDK-R)

## Instruction Manual

Please read this manual before using KYOKUTOH'S High Speed Tip Dresser (CDK-R)



# REVISION

## Revision history

---

Version	Date	Contents
First edition	09.26.2008	First edition issue
Revised edition	03.04.2019	Change of Contacts Change of Address in China
Revised edition	May.2019	Format Change
Revised edition	24.02.2021	Change of Maintenance
Revised edition	25.03.2021	Change of Parts List
Revised edition	27.03.2023	Change of Contacts



# ATTENTION TO SAFETY

**Please be sure to read ATTENTION TO SAFETY before using CDK-R**



This product is intended only for the dressing of specified electrodes. This product is not to be used in any manner other than that which is specified within. We will not be held responsible for damage or injury caused as a result of misuse of this product.

## SYMBOLES

This following symbols "Warning" and "Caution", are used indicate possible hazards and to prevent their occurrence.














 Warning	Be careful to follow directions as specified, as an error could lead to possible injury or death.
 Caution	Be careful to follow direction as specified, as an error could lead to malfunction and serious damage.


**The following symbols are explained below.**







	This symbol indicates operations that should not be done.
	This symbol indicates operation that should be done.

※After reading, please the manual to the place where you can check the manual.

 Warning

<p> Absolutely never disassemble or reconfigure this machine or its parts.</p> <ul style="list-style-type: none"> <li>○ <b>This could result in operation malfunction, ignition, or injury.</b></li> </ul>	<p> Do not insert a finger or hand into gear opening while in operation.</p> <ul style="list-style-type: none"> <li>○ <b>This will result in serious injury.</b></li> </ul>
<p> Avoid as much contact with water as possible.</p> <ul style="list-style-type: none"> <li>○ <b>This could result in operation malfunction (short), electrical shock or ignition.</b></li> </ul>	<p> Do not insert metallic articles such as a pins or needles in gear or terminal box opening.</p> <ul style="list-style-type: none"> <li>○ <b>This could result in operation malfunction or electrical shock.</b></li> </ul>
<p> Be sure to switch off the power supply, when removing or repairing wiring.</p> <ul style="list-style-type: none"> <li>○ <b>Will cause electrical shock.</b></li> </ul>	<p> Be sure that spatter does cover any wiring.</p> <ul style="list-style-type: none"> <li>○ <b>This will prevent the melting of wire membrane and a potential shock hazard.</b></li> </ul>
<p> Remove the spatter, which covers the tip dresser periodically.</p> <ul style="list-style-type: none"> <li>○ <b>Spatter build-up can cause operation malfunction or ignition resulting in injury.</b></li> </ul>	<p> Do not use acidic or chlorine detergents for maintenance purposes.</p> <ul style="list-style-type: none"> <li>○ <b>Poisonous gas may be generated from the detergents, causing a possible health risk.</b></li> </ul>
<p> Remove any oil that may accumulate on the tip dresser.</p> <ul style="list-style-type: none"> <li>○ <b>Spatter could cause ignition and possible Injury.</b></li> </ul>	<p> Do not use voltage other than that which is specified.</p> <ul style="list-style-type: none"> <li>○ <b>Excess heat could cause operation malfunction and ignition.</b></li> </ul>
<p> Be sure wire from power supply is of correct capacity. (10A/1unit)</p> <ul style="list-style-type: none"> <li>○ <b>Incorrect wiring could result in operation malfunction or ignition</b></li> </ul>	<p> Use wiring of enough thickness. (2 sq mm or more)</p> <ul style="list-style-type: none"> <li>○ <b>Incorrect wiring could result in operation malfunction or ignition</b></li> </ul>
<p> Do not allow power supply wiring to become damaged.</p> <ul style="list-style-type: none"> <li>○ <b>Wiring damage could result in operation malfunction and ignition.</b></li> </ul>	

 Caution

<p> Firmly fix tip dresser to stand.</p> <ul style="list-style-type: none"> <li>○ <b>If the Tip Dresser is not fixed tightly in operation, poor dressing and other problems could occur.</b></li> </ul>	<p> Be sure that the motor is not locked up.</p> <ul style="list-style-type: none"> <li>○ <b>This could result in overheating and possible ignition.</b></li> </ul>
<p> Do not use any cutter or holder other than that which is intended and specified.</p> <ul style="list-style-type: none"> <li>○ <b>Use of an unspecified cutter or holder, could result in damage.</b></li> </ul>	<p> Do not install near the thermal generation source of the welding machine.</p> <ul style="list-style-type: none"> <li>○ <b>This could cause trouble and accidents.</b></li> </ul>
<p> Do not install between a welding machine and a transformer.</p> <ul style="list-style-type: none"> <li>○ <b>Strong magnetic forces and heat can be dangerous and possibly cause malfunctions or ignition.</b></li> </ul>	<p> Do not use rotation direction beside set.</p> <ul style="list-style-type: none"> <li>○ <b>This could cause trouble and accidents.</b></li> </ul>

# TABLE OF CONTENTS

CDK-R Tip Dresser Capabilities	1
Criteria for Dressing Guns	2
Cautions for Positioning the Dresser 1	4
Cautions for Positioning the Dresser 2	6
Wiring to the Dresser	7
Cutter Capacity and Dressing Time	8
Timing Chart	9
Drawing	10
Parts List	11
How to Change the Cutter	12
Mounting arrangement of the Rotation Sensor (Optional Extras)	14
Timing Chart for the Rotation Sensor	15
Example Ladder Program for the Rotation Sensor	15
Cautions and Confirmation before the Operation	16
Abnormality and How to Repair	17
Consumption Parts List	19
Periodic Maintenance	20
Contacts	22

## CDK-R Tip Dresser Capability

MODEL	POWER	FREQ	CURRENT	RPM	TORQUE	POWER	RATED TIME	MASS KG
CDK-R 200V WIRE	AC200V	50 Hz	4.6 A	228 rpm	34.4 N.m	1kW	RATED OUTPUT CONTINUOUS USE TIME 5 MINUTES	17.8 kg
	AC200V	60 Hz	4.4 A	273 rpm	28.7 N.m			
	AC220V		4.2 A	276 rpm	28.7 N.m			
CDK-R 400V WIRE	AC380V	50 Hz	2.4 A	225 rpm	38.3 N.m			
	AC400V		2.3 A	228 rpm	37.7 N.m			
	AC415V		2.3 A	230 rpm	37.5 N.m			
	AC400V	60 Hz	2.2 A	273 rpm	31.5 N.m			
	AC440V		2.1 A	276 rpm	31.1 N.m			

※Dresser motor and terminal box have protection structure.

IEC STANDARD    IP54 APPROVED

### Features

1. Dress upper and lower tips simultaneously, therefore, dressing time is reduced.
2. Our KTW cutter enables cap tips to be dressed with the pressure between 1078N (110kgf) and 1960N (200kgf); furthermore, our cutter for high-pressure gun makes it possible to use higher pressure between 1960N (200kgf) and 2450N (250kgf).
3. Floating mechanism greatly reduces stress on welding gun and dresser.
4. KTW cutter reduces dressing time.

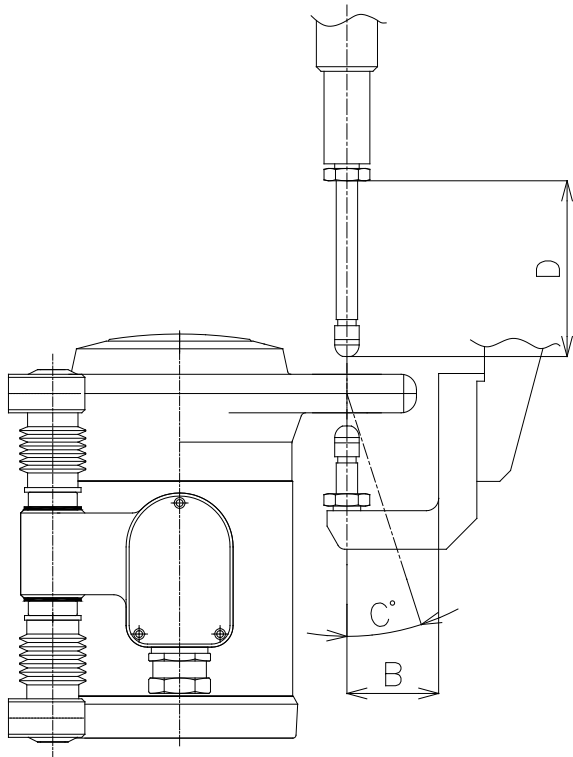
# Criteria for Dressing Guns

## Conditions that can be dressed

(Applicable to both X-guns and C-guns; see figure 1 and 2)

1. If A dimension is less than 30mm, this dresser is not suitable, because it may contact gearbox.  
✘Some special cutters require up to 35 mm.
2. If B dimension is less than 50mm, this dresser is not suitable, because it may interfere with gearbox.
3. Cap tip with "C" angle up to 15 degrees can be dressed.  
When using the eccentric tips or guns with angle, please contact us.
4. When the length of shank of D dimension is long, contact us for solution.
5. The base tip and insert electrode requires a particular cutter. (E dimension)  
We will customize the cutter if you could provide us the gun and tip drawings.
6. Recommended dressing force is between 1,078N and 1,470N.  
(Dress up to 110kgf to 150kgf)
  - When dressing pressure is less than 1,078N, there is possibility of dressing defective because of dressing amount reduction.
  - High dressing pressure from 1470N to 2450N might make the dresser stop or damage the cutter and holder, depending on the shape of cap tips. In this case, please reduce the dressing pressure. If it is impossible to reduce the pressure, please contact us. We would offer you some other special cutters.
  - It is necessary to reduce dressing pressure when it is more than 2,450N.
7. Select a cutter well suited to the tip shape.
8. For other specifications for the CDK-R, please contact our sales department.

**Figure 1**

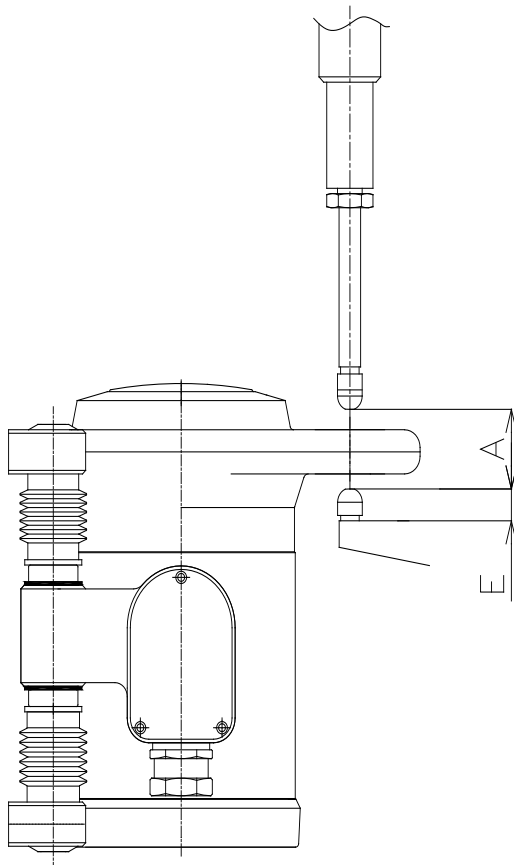


D. Concentricity guide required,  
If this is over 90mm —  $\phi 16$   
70mm —  $\phi 13$

C. Maximum 15 degrees is acceptable.

B. To avoid interference with gearbox, 50mm.

**Figure 2**



A. Tip opening needs over 30mm.

E. The special cutter should be used  
for the shorter tips.

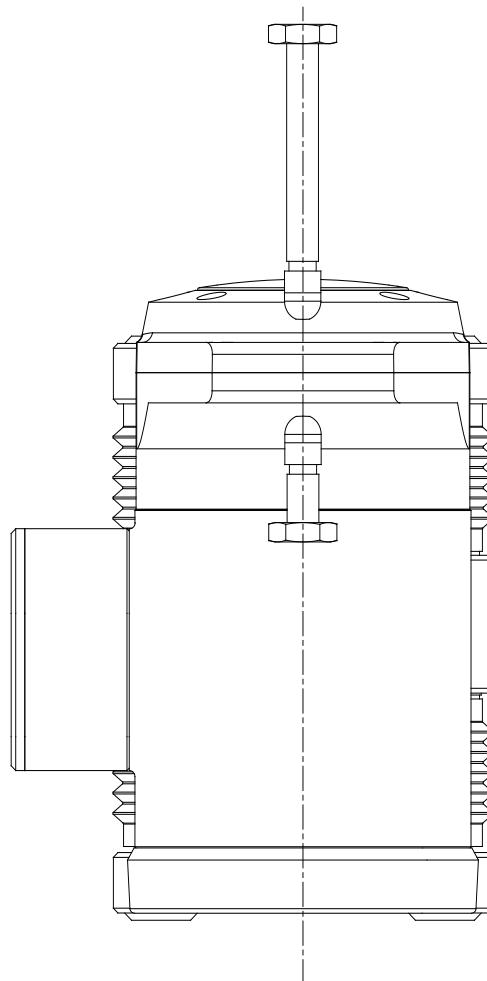


# Cautions for Positioning the Dresser 1

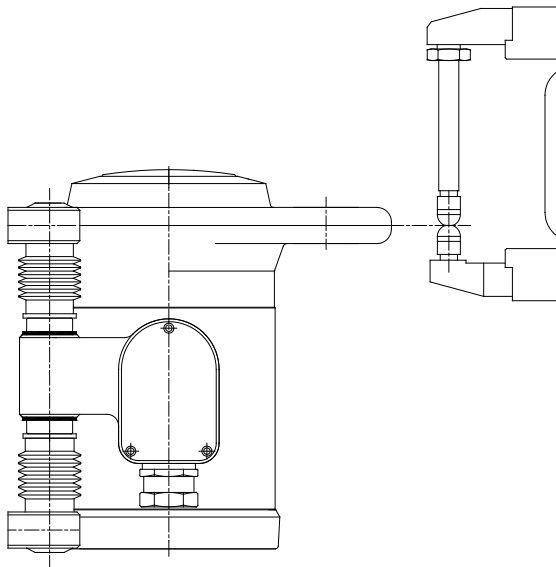
## ATTENTION

1. The tip should be set parallel to floating mechanism. (See figure 3)
2. For X-guns, set the dressing location to the pressurization location. (See figure 4)
3. For C-guns, set the dressing location even level with pressurization location, otherwise it might cause poor dressing or damage gears and bearings.
4. Although the floating mechanism is installed in dresser, we also recommend that you locate the dressing position as closely as possible.
5. Dressing horizontally C-Guns vertically set with equalizing mechanism is difficult to keep weight balance of springs, and pressurization point could easily change. So in this case, please make sure of pressurization point very well when you teach robots. (See figure 4 and 5)

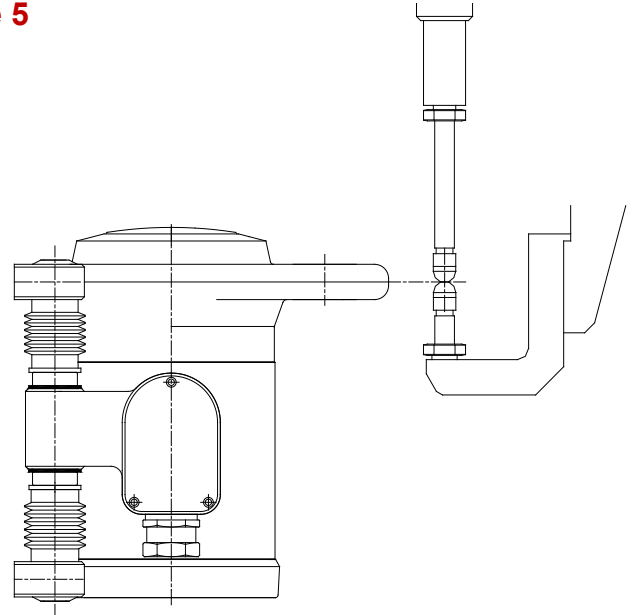
**Figure 3**



**Figure 4**

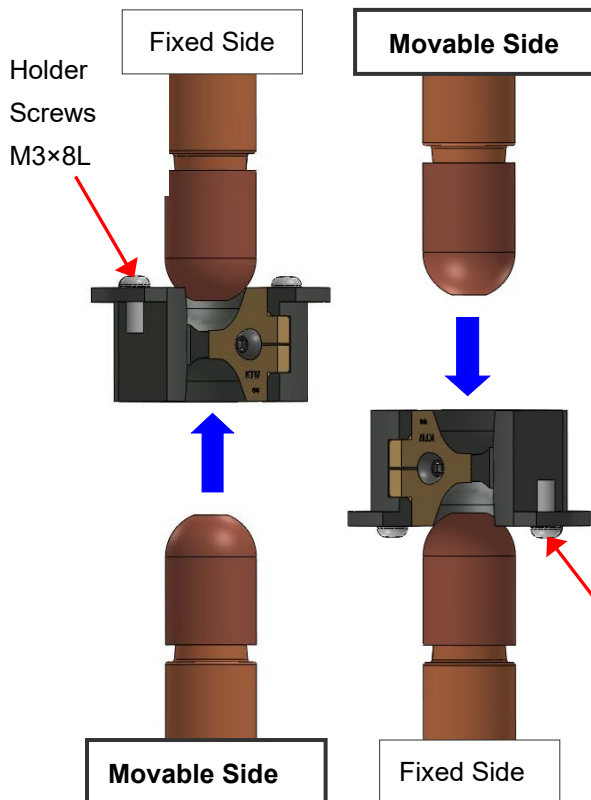


**Figure 5**

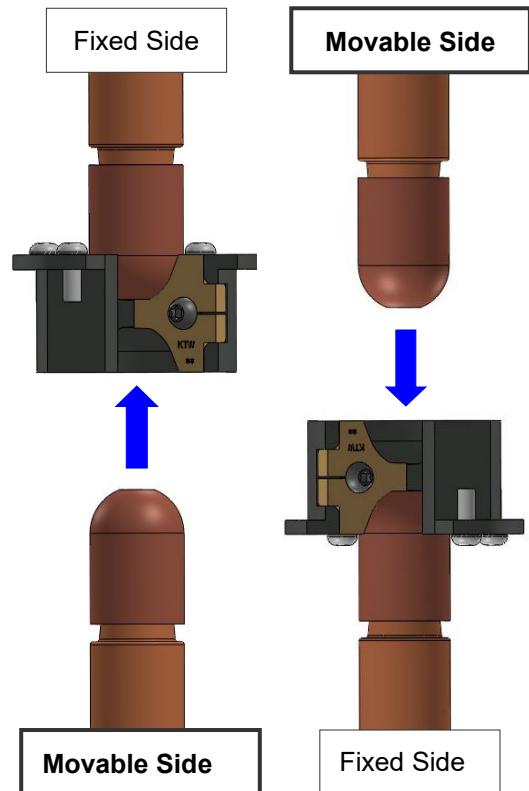


**"ATTENTION" for dress teaching**

< Picture 1 > **(Incorrect)**



< Picture 2 > **(Correct)**



※Please don't make room between a cap on a fixed side and a cutter blade as picture 1 shows. It would cause screw heads broken off and a holder fallen off once the holder is pushed up or pushed down from the bottom side of the holder. Please have a cap touch on a cutter blade as a picture 2 shows for a proper dress teaching.

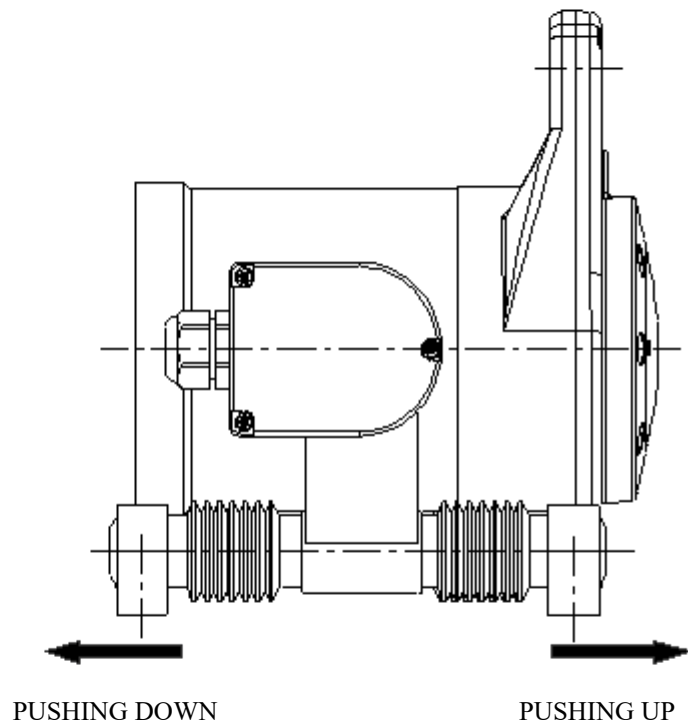
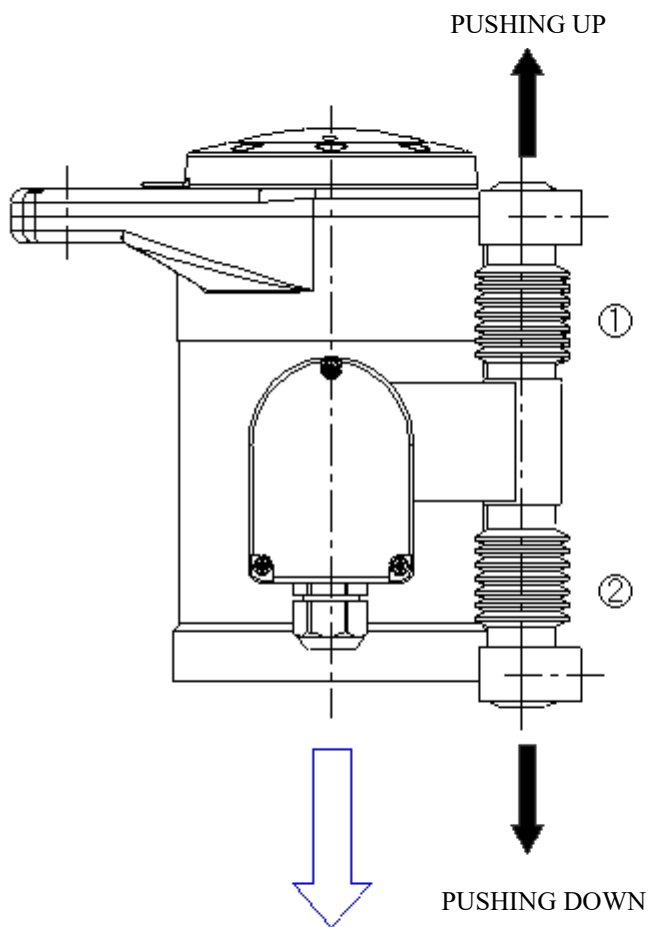
## Cautions for Positioning the Dresser 2

\* Perpendicular to Floor

\* Horizontal to Floor

<Floating amount>  
Pushing up → **19mm**  
Pushing down → **23mm**

<Floating amount>  
Pushing up → **15mm**  
Pushing down → **27mm**



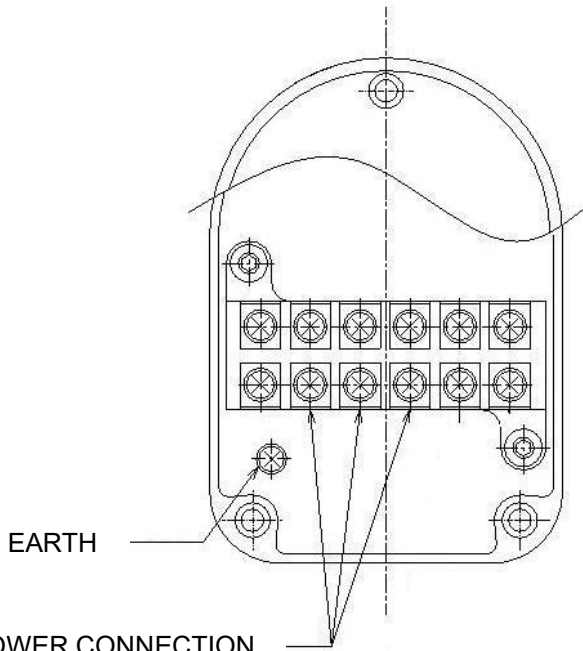
Perpendicular to the float

Because of gravity on ②, use longer spring than ①.

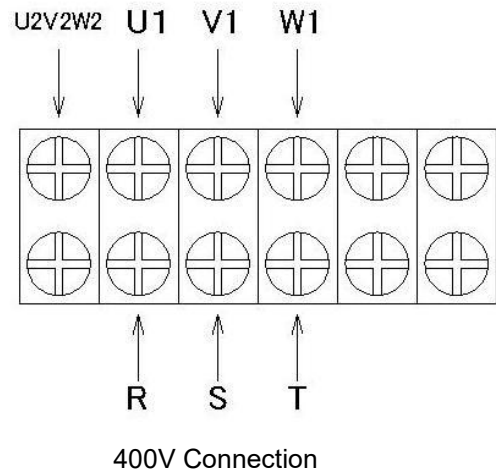
※For use of up-side-down, please replace ①,② springs.

# Wiring to the Dresser

## Terminal Diagram

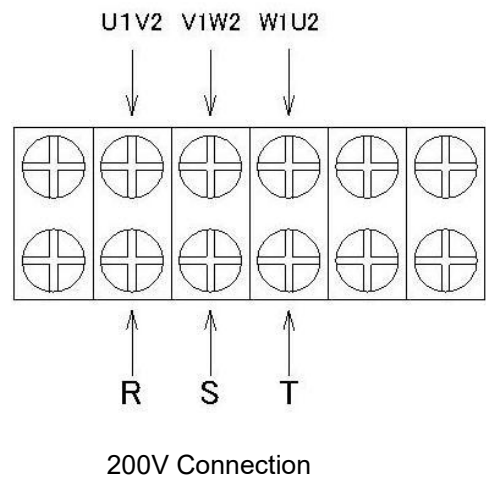
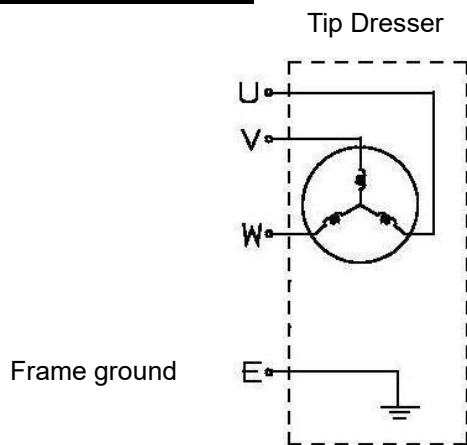


## Circuit drawing for each voltage



POWER CONNECTION

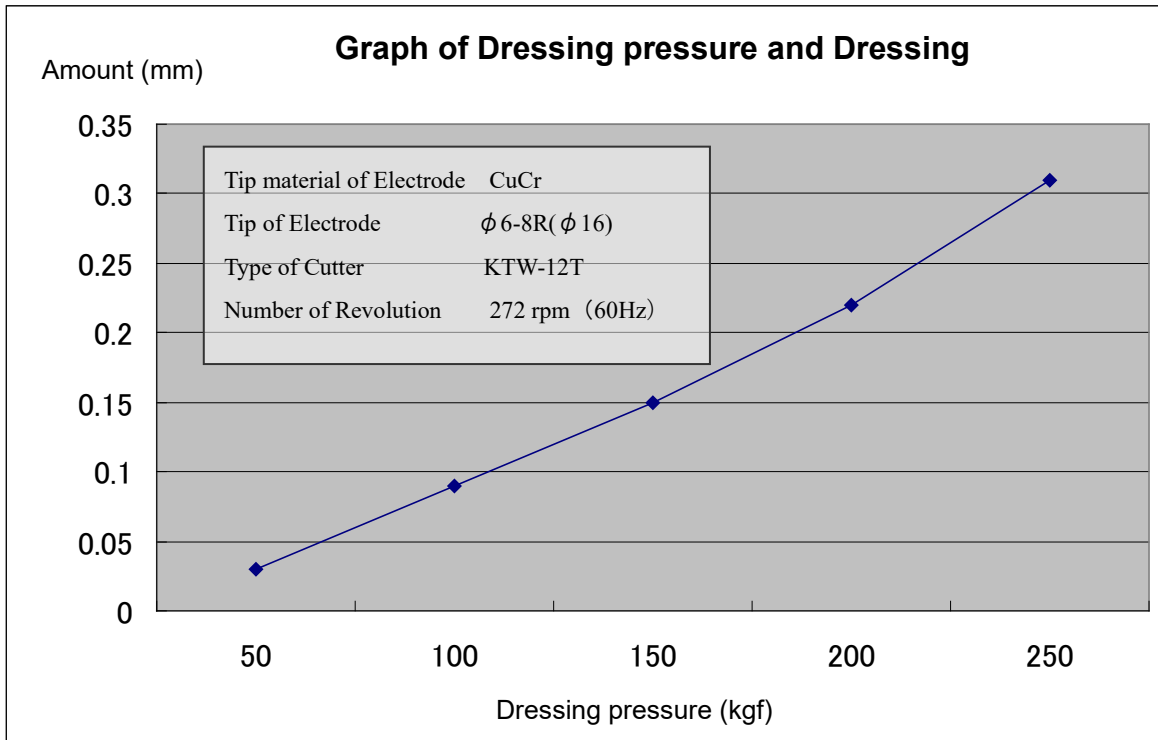
## Motor circuit diagram



- Use over 2sq power wire. (AWG Gauge NO14 equivalent)
- For power wire, recommended to use round crimp contact (2-S4).
- Do not wire when the switch is on. (Be sure to turn off the switch.)
- The operator must have the certification approved as an electrical worker.
- Please take the cable's change (shrinkages or slack) into consideration when wiring because the floating mechanism is installed on K-type dresser.
- Because the floating mechanism is installed, make sure the terminal bolt is tightened.  
(We recommend that you make a circle with cable beside the dresser in order to absorb the vibration.)

✘Set the overloading protector the outside.(Ex.Thermal)

# Cutter Capacity and Dressing Time



## Estimated Dressing Time

Dressing time: 1 sec

Please adjust dressing time and pressure according to above graph.

- Example 1: to dress 0.1mm
  - Dressing time: 1 sec
  - Dressing pressure: 110kgf
- Example 2: to dress 0.1mm
  - Dressing time: 0.7 sec
  - Dressing pressure: 150 kgf

Above examples are rough indications for the default. If you find cap tips are dressed not enough or too much while using, please adjust the setting to your cap tips.

● Average dressing cycle of KTW cutters after 200 welds is 1 to 2 seconds.

## ATTENTION

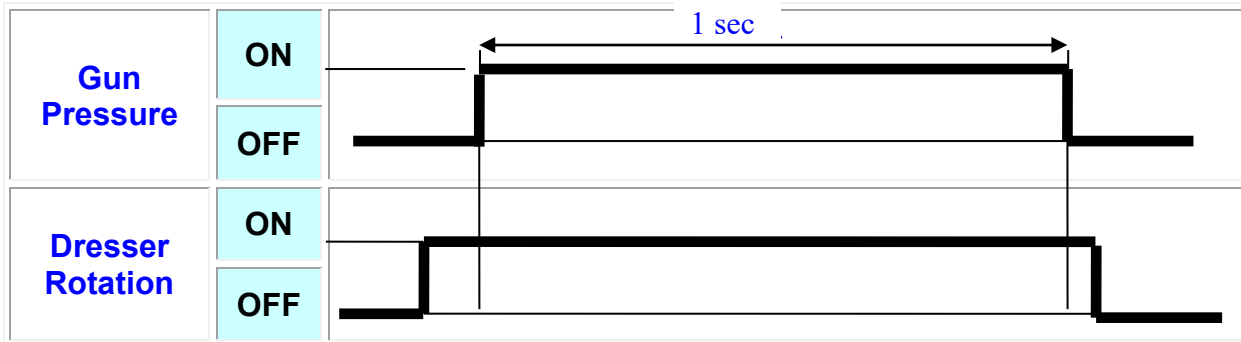
**It might cause a chip clogging if a dressing time is more than 1 sec. If dressing time is required more than 1 sec, it is recommended to be dressed multiple times to avoid chip clogging.**

**For example: If need 2 sec dressing time → 1 sec x 2 times dressing**

We have various types of cutters with different shapes and different metallic finishing for optimum dressing. So even if you changed the length of dressing time or the amount of dressing pressure and still couldn't get better result, please contact us.

# Timing Chart

## KTW type Cutter (Only clockwise rotation)

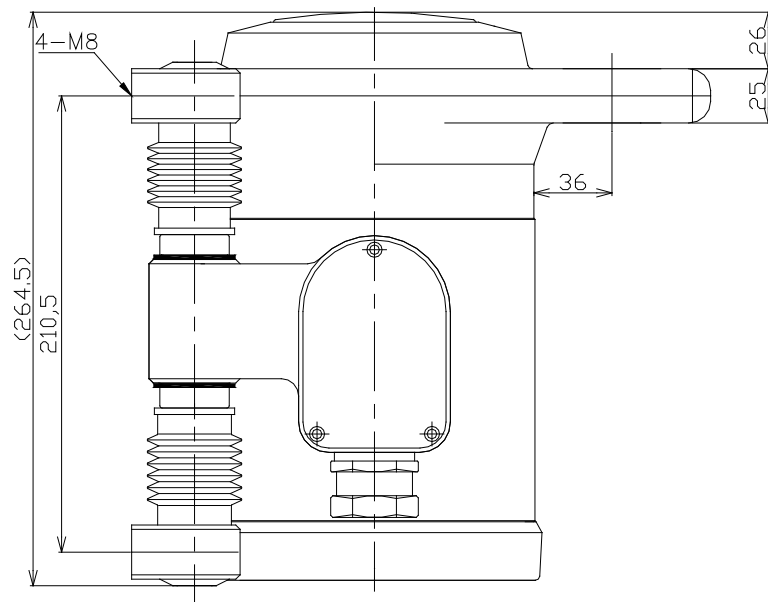
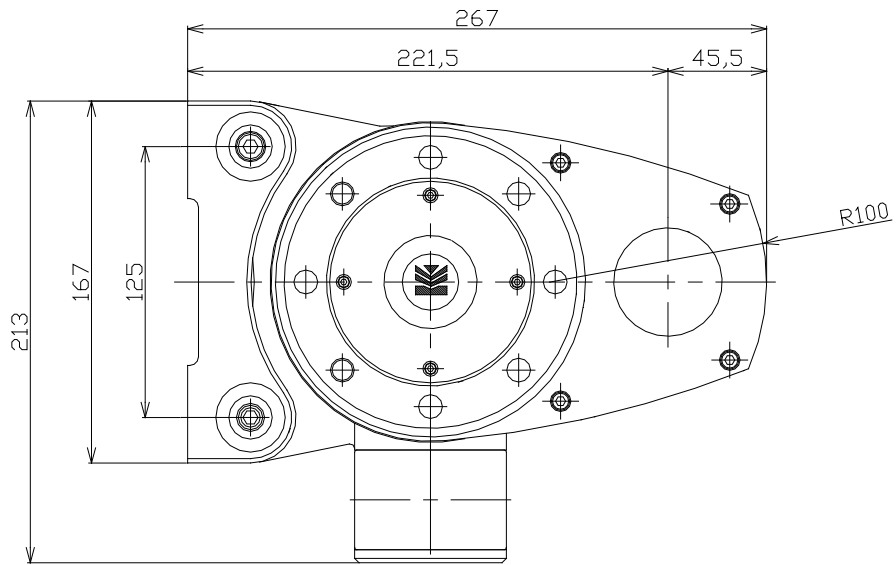


- ① Start motor to clockwise before Gun press.
- ② Set the dressing time according to your tip condition. Approximately **MAX 1sec.**
- ③ Confirm rotate direction (clockwise).
- ④ To finish dressing, release the gun pressure while dresser is revolving.

Before operating, make sure that the forms of cutter and tip are fitting.

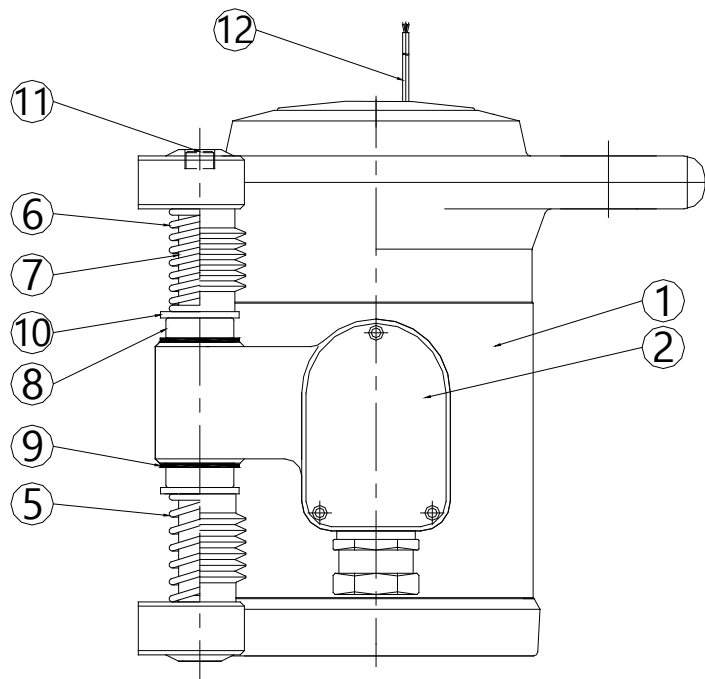
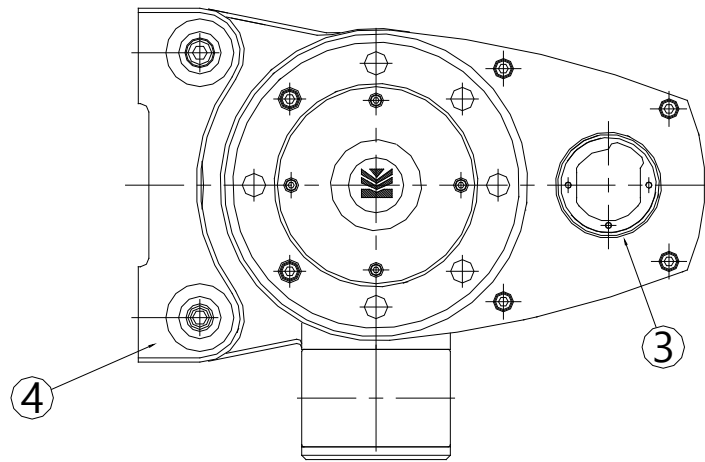
When dressing is finished and small scrapes are left on the cap tips, both upper and lower tips should be touched with the cutter of revolving dresser before returning to original position.

# Drawing



# Parts List

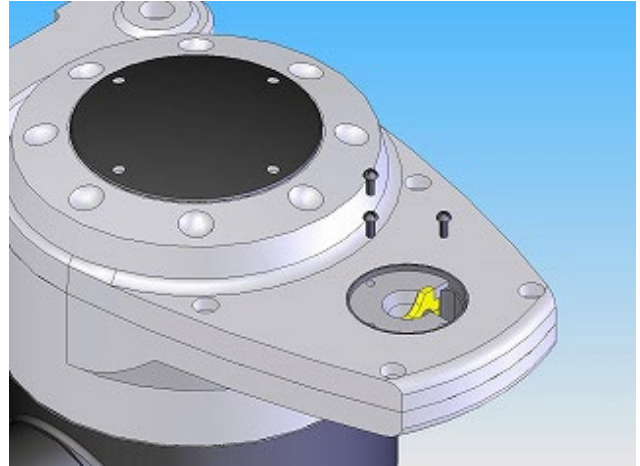
NO.	Parts Name	Type or Size	QTY
1	Tip Dresser	CDK-R	1
2	Terminal Box	Include Motor	1
3	Output Bearing	6809LLB	2
4	Shaft Plate	CDK-R-001	2
5	Spring for Vertical Type	CDK-R-002	2
	Spring for Horizontal Type	CDK-R-003	2
6	Upper Spring	CDK-R-003	2
7	Shaft	CDK-R-004	2
8	Slide Bearing	LM20LUU	2
9	C-Ring for Bearing	For 32 Axis	4
10	Flat Washer	For M20	4
11	Cap Screw	M8 X 20	4
12	Rotation Sensor (Optional Extras)	RS-KBAYOSG-PF-M8-2M	1



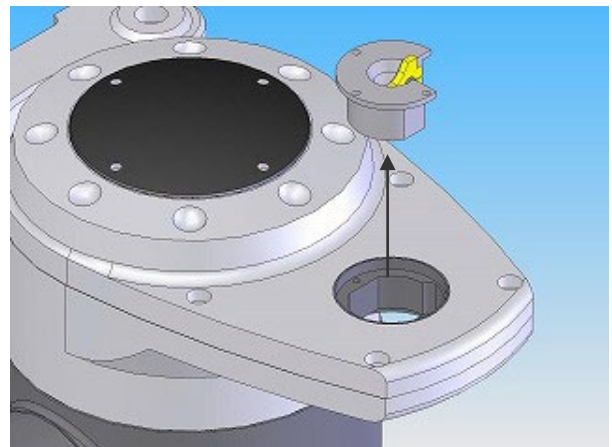


## How to Change the Cutter

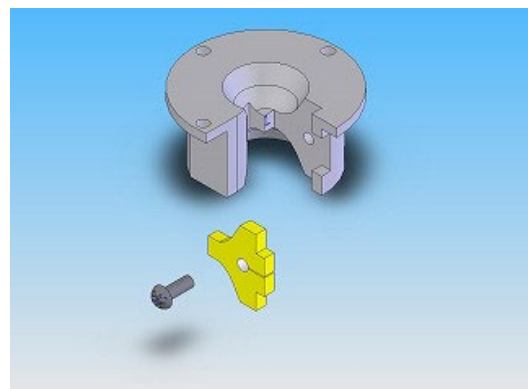
1. Remove M3 screws from the cutter holder.  
※Recommended torque for M3 screw is to 0.95N · m



2. Remove the cutter holder from the dresser.



3. To remove the cutter from the cutter holder, loosen the M3 torque screw.  
(With a torque wrench T-10)



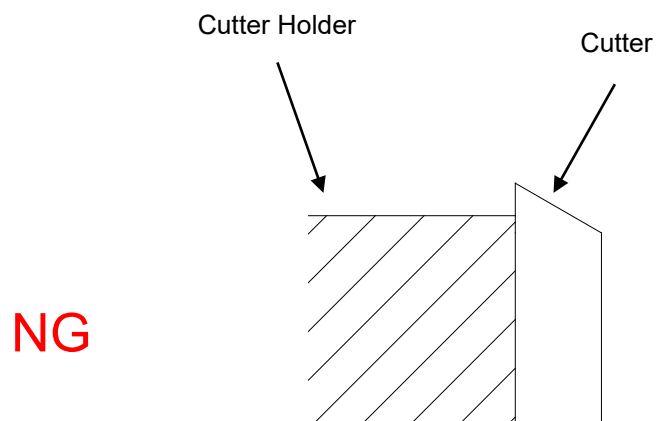
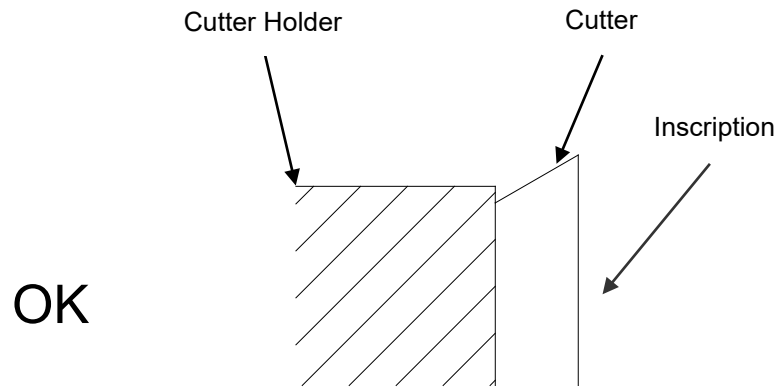
4. Replace a new cutter

Confirm cutter is replaced in the proper direction.

Please install the angle narrow on the side where touches the holder.

(Inscription faced up)

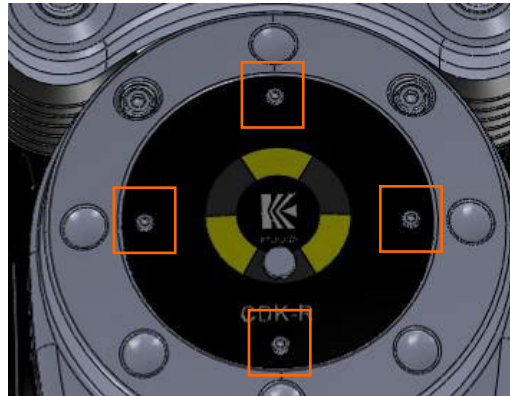
(Recommended torque for M3 screw is to 1.0~1.2N · m).



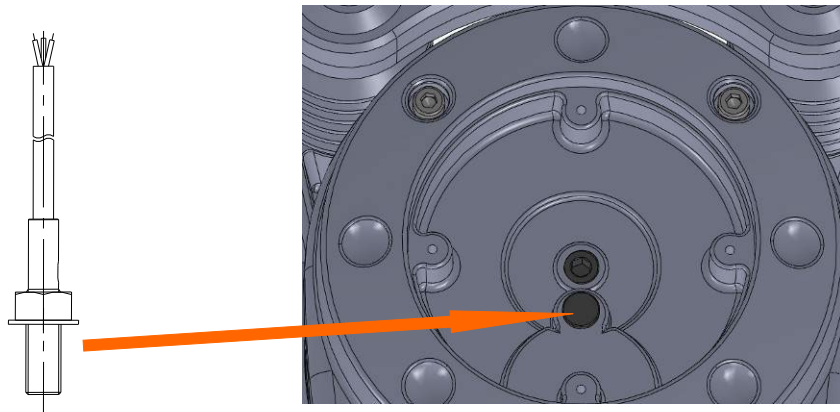
5. To install the cutter holder to the dresser, please do the reverse order from 1 to 2.

## Mounting arrangement of the Rotation Sensor (Optional Extras)

1. Remove the nameplate (M3×4).



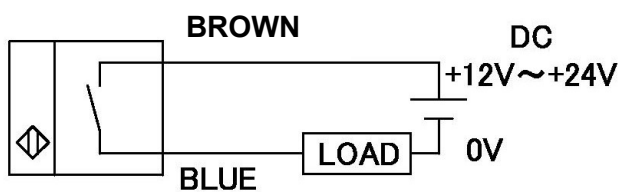
2. Remove the Plug and install the Rotation Sensor.  
(Set optionally)



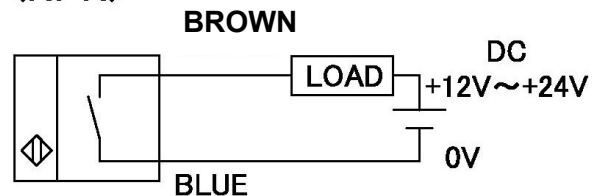
3. Replace the nameplate.

4. Following the wiring color, wire the sensor.

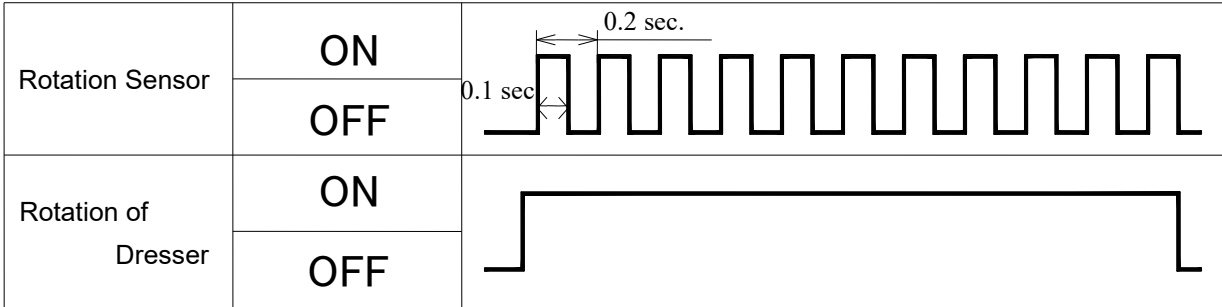
<PNP>



<NPN>



# Timing Chart for the Rotation Sensor

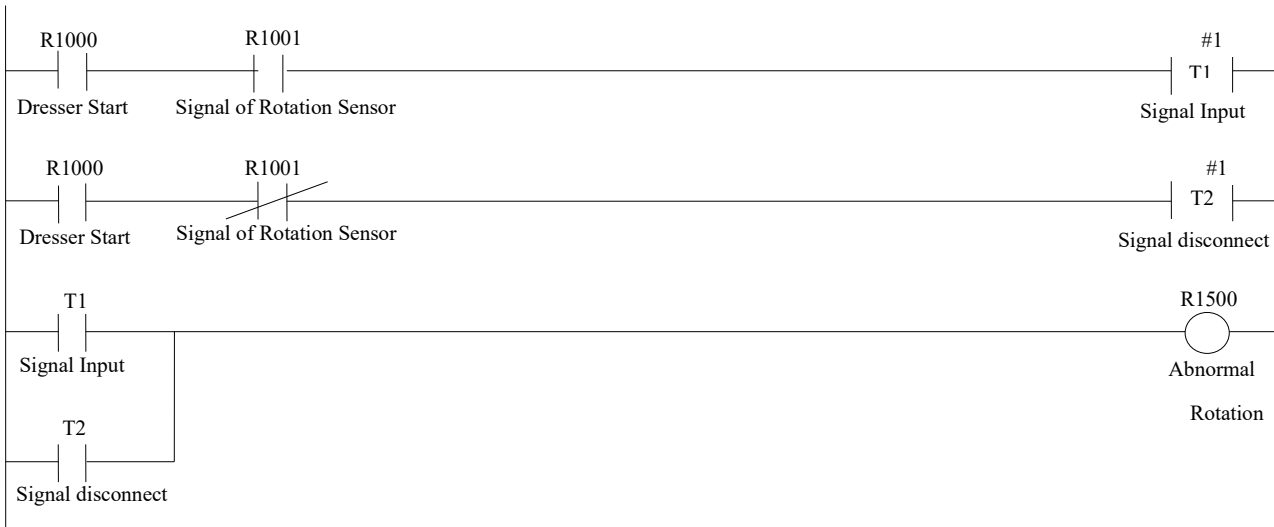
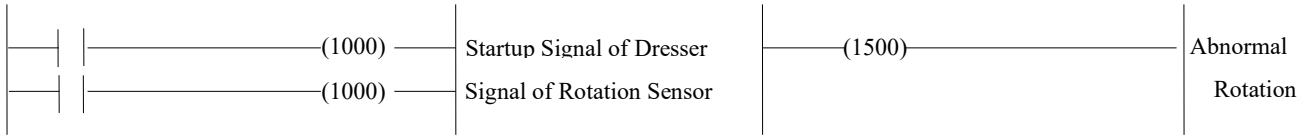


While the dresser is revolving, the sensor sends out signals 1pulse/0.1 sec.. We recommend that more than 0.5 sec. input or cutting of signal, including initiation delay, should be considered as abnormal rotation.

# Example Ladder Program for the Rotation Sensor

[PLC (Robot) Input side]

[PLC (Robot) Output side]



#5=0.5 sec.

## Cautions and Confirmation before the Operation

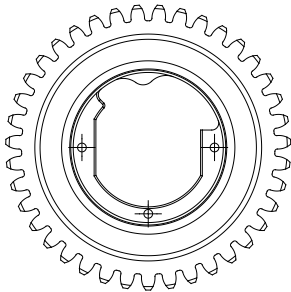
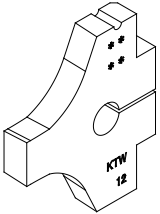
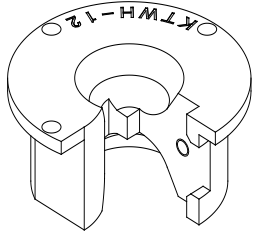
1. Confirm the specification again. (Voltage, option, etc)
  2. Make sure of the conformity between the forms of cutter and cap tips.
  3. Install the dresser in the place where the operator can not touch it directly during the operation.
  4. Make sure dresser and stand bolts are tightened firmly. Also, confirm stand is fixed securely to the floor.
  5. When connecting wires to the dresser, operation procedures must be followed with the electric construction standard and also make sure that it is protected from cooling water and spatter.
  6. Be certain dresser is grounded.
  7. Make sure dresser is installed in a location with no spatter and cooling water directly.
  8. Confirm the forms of the cutter and cap tips once again before robot teaching, Confirm that cutter and holder are securely fastened.
  9. Confirm the rotation direction of the KTW cutter is clockwise.
  10. Make sure there is neither interference to the dresser except for the cap tips, nor any allophone when robot teaching.
  11. When the gun is pressurized, make sure that the electric current is not applied and pressure is within the setting range.
  12. Confirm the quality of the dressed tip. Be sure that the shank is stable and not shaking during dressing.
- ◆ The causes of the failure in dressing.
- The gun is not released while the dresser is revolving. (Scrapes are left on the cap tips)
  - The pressure is too high or too low.
  - The forms of the cap tip and the cutter are not fitting.
  - The dressing time is too short.
  - The teaching point differs from the dressing one.
  - The shape of used cap tips differs from new ones too much.
- ◇ If the cap tips can't get dressed properly with any other reason, please contact us.

## Abnormality and How to Repair

Abnormal Condition	Cause and Countermeasure
Dresser does not rotate.	<ul style="list-style-type: none"> <li>* The power switch is OFF. → Check the power source.</li> <li>* Wire is cut-off or poor contact. → Check the terminal box and control panel.</li> <li>* The thermostat fuse of motor side is working. → Check the motor and reset it after cooling down.</li> <li>* The gun pressure is higher than specified by our company. → Set gun pressure under 1960N(200kgf).</li> <li>* Motor is broken. → Need repair to replace the motor.</li> <li>* The shapes of the cutter and the cap tip are not fitting, and cling each other. → Check the cutter shape and replace it if necessary.</li> </ul>
The motor is running but the cutter does not rotate.	<ul style="list-style-type: none"> <li>* Gear in the gear box is broken. → Need repair to replace the gear.</li> </ul>
The diameter of the dressed cap tip is different from the setting.	<ul style="list-style-type: none"> <li>* Dressing time is too short. → Set the dressing time to the tip that has been crushed most.</li> <li>* The cutting capability of the cutter has deteriorated or the cutter has been damaged. → Replace the cutter and check the gun pressure.</li> <li>* Dressing point is not proper. → Re-do teaching.</li> <li>* The cutter is not suitable for the cap tip. → Check the cutter shape and replace it if necessary.</li> <li>* Gear in the gear box is broken. → Need repair to replace the gear.</li> <li>* The screw which fastens the cutter to the holder is loosen. → Tighten the screw.</li> </ul>
Abnormal sound during dressing.	<ul style="list-style-type: none"> <li>* Dressing point is not proper. → Re-do teaching.</li> <li>* The cutter has been damaged. → Replace the cutter and check the gun pressure.</li> </ul>

Abnormal Condition	Cause and Countermeasure
Dresser leaves burr on the cap tip.	<ul style="list-style-type: none"> <li>* The control method is not proper. → Release the gun while dresser is revolving, and then stop the dresser.</li> <li>* The shapes of the cutter and the cap tips are not fitting. → Check the cutter shape and replace it, if necessary.</li> <li>* The cutter has been damaged. → Replace the cutter and check the gun pressure.</li> <li>* The screw which fastens the cutter to the holder is loosen. → Tighten the screw.</li> </ul>
The tip diameter is not at the center or the designated location.	<ul style="list-style-type: none"> <li>* The cap tip has got too short. → Replace the cap tip to new one.</li> <li>* Dressing position is not proper. → Re-do teaching.</li> </ul>
The point of the cap tip is an oval, not a circle.	<ul style="list-style-type: none"> <li>* The bolts that fasten the motor and the gear box are loosen. → Tighten the bolts.</li> <li>* The bolts that fasten the dresser to the stand are loosen. → Tighten the bolts</li> </ul>
Dressing does not complete in the set time	<ul style="list-style-type: none"> <li>* The cutting capability of the cutter has deteriorated or the cutter has been damaged. → Replace the cutter and check the gun pressure.</li> <li>* Dressing time is too short. → Set the dressing time to the cap tip that has been crushed most.</li> <li>* The cap tip is soften after welding, the point of the cap tip gets widened. → Increase the dressing pressure gradually according to the time of dressing a cap tip when it is with gun voltage valve.</li> </ul>
<p>&lt;Remarks&gt;</p> <ul style="list-style-type: none"> <li>● Please be sure the switch is off when you are checking or replacing parts or the cutter.</li> <li>● When the dresser is out of order, please contact us immediately. Do not take the dresser apart. It would not be able to repair if you disassemble it.</li> </ul>	

## Consumption Parts List

<div style="border: 1px solid black; padding: 5px; display: inline-block;">Outsourced Product</div>	<p>* Bearing for tip dresser Type : 6809LLB</p> <p>Replacement Qty: 2pcs. Replacement cycle: 5 years</p>
	<p>* Output gear with bearing for KTW cutter. Type : CDK-R-D-KTWHL</p> <p>Replacement Qty: 1pc. Replacement cycle: 5 years</p>
	<p>* Cutter Type : KTW-**</p> <p>Replacement Qty: 1 pc. Replacement cycle: Total dressing time, 10,000sec.</p>
	<p>* Cutter holder Type : KTWH-**</p> <p>Replacement Qty: 1 pc. Replacement cycle: Total dressing time, 30,000sec.</p>



## Periodic Maintenance

Maintenance place	How to maintenance
To the gearbox, grease supply	<p>Remove the nameplate. Remove 1/8 screw from the upper side of the gearbox. Install grease nipple. Supply the greased with grease gun. Grease: Water-resistant industrial grease, NLGI No.1 (that has excellent anti-corrosion and water resistance, which is suitable to be used in wet and damp environments.) Lubricate once a year with 20 g (approx. 0.8 oz) for each. Prevent foreign matter (e.g., cut pieces of wire, sputtering welding materials, iron chips, wire, and dust) from entering the equipment.</p>

**MEMO**

# Contacts

**Contact us if there is any damage or machine defects in our products.**



## **KYOKUTOH CO., LTD**

181-1, Nakayashiki, Orido-cho, Nisshin, Aichi 470-0115  
Japan

TEL +81-561-72-8811 FAX +81-561-72-8821

E-Mail: [sales@kyokutoh.com](mailto:sales@kyokutoh.com)

<http://www.kyokutoh.com>

## **SAITAMA Office**

TEL +81-49-277-4324 FAX +81-49-277-4325

## **KANAGAWA Office**

TEL +81-46-204-9260 FAX +81-46-204-9261

## **HIROSHIMA Office**

TEL +81-82-569-6227 FAX +81-82-569-6228

## **FUKUOKA Office**

TEL +81-92-410-6977 FAX +81-92-410-6988



## **CHANGER & DRESSER CORPORATION**

1527 ITC Way, Anniston, AL 36207 U.S.A

TEL +1-256-832-4392 FAX +1-256-832-4393

<http://www.changer-dresser.com>



## **KYOKUTOH CHINA**

73 Huagang Street, Xiuquan Town, Huadu District,  
Guangzhou City, Guangdong Province, China.

TEL +86-20-86980880 FAX +86-20-86980890

<http://www.kyokutoh.com.cn>



## **KYOKUTOH THAILAND**

339/2 Soi Phattanakarn 69, Phattanakarn Road, Prawet,  
Bangkok 10250 THAILAND

TEL +66-272-162-82 FAX +66-272-162-84

<http://www.kyokutoh.co.th>



## **KYOKUTOH KOREA**

117, Tawon TAKRA II Industry Center, Dongsan-ro 76,  
Danwon-gu, Ansan-si, Gyeonggi-do, Korea 15434

TEL +82-31-414-8730 FAX +82-31-414-8731



## **KYOKUTOH EUROPE**

Max-Planck-Str.4 59423 Unna Germany

TEL +49-2303-93-615-00 FAX +49-2303-93-615-29

<http://www.kyokutoh.de>



**KYOKUTOH WELD INDIA**

Office No.19, 3rd Floor, Aditya Centeegra, FC Road, Deccan,  
Pune - 411004

TEL +91-20-68297011 FAX +91-20-68297011

---

